

SkyLine Chills Blast Chiller-Freezer 61 (66 lbs)

ITEM # _____

MODEL # _____

NAME # _____

SIS # _____

AIA # _____



727731 (EBFA61TQ)

SKYLINE Chills 66 LBS 6
 HALF SHEET PANS (12" X
 20") REACH-IN

Short Form Specification

Item No. _____

- Blast chiller freezer with high resolution full touch screen interface, Multilanguage, IP54, ERGOcert, ETL
- OptiFlow air distribution system with 7 fan speed levels
- 3 modes: Automatic (10 food families with 100+ different pre-installed variants); Programs (1000 programs can be stored and organized in 16 different categories); Manual (soft chilling, hard chilling, freezing, holding, turbo cooling and lite hot cycles);
- Special Cycles (Cruise A.R.T.E chilling, proving, retarded proving, fast thawing, Sushi&Sashimi, Sous-Vide chilling, ice-cream, yogurt and chocolate)
- Special functions: MultiTimer, Make-it-Mine, SkyHub homepage, agenda MyPlanner, SkyDuo connection to SkyLine ovens
- Automatic and manual defrosting and drying
- USB port to download HACCP data, programs and settings. Connectivity cloud ready
- 3-point multi sensor core temperature probe
- Built-in refrigeration unit
- R448a refrigerant gas

Main Features

- Blast Chilling cycle: 66 lbs (30 kg) from +195°F (90°C) to +37°F (+3°C) in less than 90 minutes.
- Chilling cycle (50°F to -25°F/ 10°C to -31°C) with automatic preset cycles: - Soft chilling (air temperature 32°F/0°C), ideal for delicate food and small portions. - Hard chilling (air temperature -4°F/-20°C), ideal for solid food and whole pieces.
- X-Freeze: cycle (+50°F to -25°F/+10°C to -31°C): ideal for blast freezing all kinds of food (raw, half or fully cooked).
- Lite-Hot cycle (+104°F to 0°F/+40°C to -18°C): Ideal for soft heating preparations.
- Infinite Cycle: chiller works continuously at the desired temperature; ideal for continuous production.
- Automatic chilling/freezing mode including 10 food families (meat, poultry, fish, sauces and soup, vegetables, pasta/rice, bread, pastries and sweet bakery, dessert, beverage fast cooling) with 100+ different pre-installed variations. The Automatic Sensory Phase of the blast chiller optimizes the chilling process according to size, quantity and type of food loaded to achieve the selected result. Real time monitoring of chilling parameters. Personalize and save up to 70 variations per family.
- Cycles+: - Cruise Cycle (Patented EP1716769B1 and related family) automatically sets the parameters for the quickest and best chilling (it works with probe) - Proving - Retarded Proving - Fast Thawing - Sushi&Sashimi (anisakis-free food) - Chill Sous-vide - Ice Cream - Yogurt - Chocolate
- Programs mode: up to 1000 programs can be stored in the blast chiller's memory, to recreate the exact same high standard at any time. The programs can be grouped in 16 different categories to better organize the menu. 16-step chilling programs also available.
- MultiTimer: Special feature to manage up to 20 different cooking cycles at the same time in the same cavity guaranteeing even cooking results. Up to 200 MultiTimer available programs
- OptiFlow: air flow management system to achieve maximum performance in cooking evenness and temperature control thanks to the special design of the cooking chamber, the high precision variable speed fan and the venting valve.
- Cooling Fan: 7 speed levels. Fan stops in less than 5 seconds when door is opened.
- 3-point multi sensor core temperature probe for high precision and food safety.
- 6-point multi sensor core temperature probe for maximum precision and food safety (optional accessory).
- A.R.T.E: Remaining time estimation for probe-driven cycles based on artificial intelligence techniques (ARTE 2.0 Patented US7971450B2 and related family) for an easier planning of the activities.
- Customization: Modify pre-cooling and pre-heating functions.
- Automatic and manual defrosting and drying.
- Multi-purpose internal structure is suitable for 6 half-sheet size pans 12" x 20" (300x500 mm)(12 positions

APPROVAL: _____

available with 1 1/5"pitch (30 mm)) or 6 bakery trays of 23" x 15" (600x400 mm)(12 positions available with 1 1/5" (30 mm) pitch). Modifiable pitch.

- Performance guaranteed at ambient temperatures of +109° F (+43°C)(Climatic class 5 certified).
- [NOT TRANSLATED]
- [NOT TRANSLATED]

Construction

- Built-in refrigeration unit.
- Solenoid valve to automatically manage the gas pressure in the thermodynamic circuit.
- Main components in 304 AISI stainless steel.
- Evaporator with antirust protection.
- Motors and fan waterproof protected IP54.
- Seamless hygienic internal chamber with all rounded corners for easy cleaning.
- Removable magnetic gasket door with hygienic design.
- Ventilator swinging hinged panel for access to the evaporator for cleaning.
- Door stopper to keep the door open in order to avoid the formation of bad smells.
- Automatic heated door frame.
- No water connections required. Waste water can be plumbed into drain, but can also be collected in an optional waste container.

User Interface & Data Management

- Touchscreen: High resolution interface (translated into more than 30 languages including Spanish and French) - color-blind friendly panel.
- Touchscreen: High resolution interface (translated into more than 30 languages including Spanish and French) - color-blind friendly panel. (only for)
- Make-it-mine: feature to allow full personalization or locking of the user interface by selecting what is visible on screen
- SkyHub:customizable homepage to allow the user to group their favorite functions for immediate access when operating.
- MyPlanner: on-screen agenda where the user can plan their daily work, set reminders for several users and receive personalized alerts for each activity
- SkyDuo: Oven and Blast Chiller automatic communication to guide the user through the cook&chill process by creating a safe controlled environment to optimize time and efficiency (requires optional accessory).
- SkyDuo: Oven and Blast Chiller automatic communication to guide the user through the cook&chill process by creating a safe controlled environment to optimize time and efficiency (requires optional accessory). (only for)
- e-learning: equipment trainings, how-to guides, and technical documentation easily accessible by scanning QR-Code with any mobile device.
- Data Analytics: automatic consumption visualization at the end of the cycle.

Sustainability



- Human centered design: with 4-star certification for ergonomics and usability.
- Holding at +37°F (+3°C) for chilling or -8 °F (-22°C) for freezing, automatically activated at the end of each cycle, to save energy and maintain the target temperature (manual activation is also possible).

Included Accessories

- 1 of Worktop for 61 blast chiller freezer PNC 880581
- 1 of 3-sensor probe for blast chiller freezer PNC 880582
- 3 of Single 304 stainless steel grid (12" x 20") PNC 922062

Optional Accessories

- | | | | | | |
|--|------------|--------------------------|---|------------|--------------------------|
| • RILSAN PASTRY GRID FOR BLAST CHILLER - 400x600MM | PNC 880294 | <input type="checkbox"/> | • Bakery/pastry tray rack with wheels 400x600mm for 6 GN 1/1 oven and blast chiller freezer, 80mm pitch (5 runners) | PNC 922607 | <input type="checkbox"/> |
| • Stacking kit for 61 combi oven on 61 blast chiller freezer - height=100mm (4") | PNC 880565 | <input type="checkbox"/> | • Trolley for slide-in rack for 61 and 101 combi oven and blast chiller freezer | PNC 922626 | <input type="checkbox"/> |
| • Worktop for 61 blast chiller freezer | PNC 880581 | <input type="checkbox"/> | • Probe holder for liquids | PNC 922714 | <input type="checkbox"/> |
| • Stacking kit for 61 previous oven generation on 61 Skyline blast chiller freezer - height=100mm (4") | PNC 880586 | <input type="checkbox"/> | • Non-stick universal pan (12" x 20" x 3/4") | PNC 925000 | <input type="checkbox"/> |
| • 5 stainless steel runners for 61 and 101 blast chiller freezer | PNC 880587 | <input type="checkbox"/> | • Non-stick universal pan (12" x 20" x 1 1/2") | PNC 925001 | <input type="checkbox"/> |
| • 4 wheels for blast chiller 61 tower execution with 61 combi oven | PNC 880676 | <input type="checkbox"/> | • Non-stick universal pan (12" x 20" x 2 1/2") | PNC 925002 | <input type="checkbox"/> |
| • 4 wheels for blast chiller freezer | PNC 881284 | <input type="checkbox"/> | • Frying griddle double sided (ribbed/smooth) 12" x 20" | PNC 925003 | <input type="checkbox"/> |
| • Pair of half size oven racks, type 304 stainless steel | PNC 922017 | <input type="checkbox"/> | • Aluminum combi oven grill (12" x 20") | PNC 925004 | <input type="checkbox"/> |
| • Chicken racks, pair (2) (fits 8 chickens per rack) | PNC 922036 | <input type="checkbox"/> | • Egg fryer for 8 eggs (12" X 20") | PNC 925005 | <input type="checkbox"/> |
| • Single 304 stainless steel grid (12" x 20") | PNC 922062 | <input type="checkbox"/> | • Flat baking tray with 2 edges (12" x 20") | PNC 925006 | <input type="checkbox"/> |
| • Stainless steel 304 grids (GN ½) with spikes, fits 4 chickens | PNC 922086 | <input type="checkbox"/> | • Baking tray for (4) baguettes (12" x 20") | PNC 925007 | <input type="checkbox"/> |
| • Baguette tray, made of perforated aluminum, silicon coated, 16" x 24" | PNC 922189 | <input type="checkbox"/> | • Potato baker GN 1/1 for 28 potatoes (12"X20") | PNC 925008 | <input type="checkbox"/> |
| • Perforated baking tray, made of perforated aluminum, 16" x 24" | PNC 922190 | <input type="checkbox"/> | • Non-stick U-pan (12" x 10" x 3/4") | PNC 925009 | <input type="checkbox"/> |
| • Baking tray, made of aluminum 16" x 24" | PNC 922191 | <input type="checkbox"/> | • Non-stick U-pan (12" x 10" x 1 1/2") | PNC 925010 | <input type="checkbox"/> |
| • Pair of frying baskets | PNC 922239 | <input type="checkbox"/> | • Non-stick U-pan (12" x 10" x 2 1/2") | PNC 925011 | <input type="checkbox"/> |
| • Pastry grid 16" x 24" | PNC 922264 | <input type="checkbox"/> | • 6 NON-STICK U-PAN (12" X 20" X 3/4") | PNC 925012 | <input type="checkbox"/> |
| • Grid for whole chicken 1/IGN (8 per grid - 2.6 lbs each) | PNC 922266 | <input type="checkbox"/> | • 6 NON-STICK U-PAN (12"X20"X1 1/2") | PNC 925013 | <input type="checkbox"/> |
| • Kit universal skewer rack & (4) long skewer ovens (TANDOOR) | PNC 922324 | <input type="checkbox"/> | • 6 NON-STICK U-PAN (12"X20"X2 1/2") | PNC 925014 | <input type="checkbox"/> |
| • Kit universal skewer rack & (6) long skewer ovens (TANDOOR) | PNC 922325 | <input type="checkbox"/> | | | |
| • Universal skewer pan for ovens (TANDOOR) | PNC 922326 | <input type="checkbox"/> | | | |
| • Skewers for ovens, (4) 24" long (TANDOOR) | PNC 922327 | <input type="checkbox"/> | | | |
| • Multipurpose hook | PNC 922348 | <input type="checkbox"/> | | | |
| • Grid for 8 whole ducks (1.8KG, 4LBS) - GN 1/1 | PNC 922362 | <input type="checkbox"/> | | | |
| • Connectivity hub (SIM) Router Ethernet + WiFi + 4G (US and Canada) | PNC 922410 | <input type="checkbox"/> | | | |
| • Connectivity hub (LAN) Router Ethernet + WiFi | PNC 922412 | <input type="checkbox"/> | | | |
| • 6 Tray Rack with wheels, Half Sheet Pans, 2 ½" (65mm) pitch for 61 ovens and blast chillers | PNC 922600 | <input type="checkbox"/> | | | |
| • 5 Tray Rack with wheels, Half Sheet Pans, 3" (80mm) pitch, for 61 ovens and blast chillers | PNC 922606 | <input type="checkbox"/> | | | |

Front

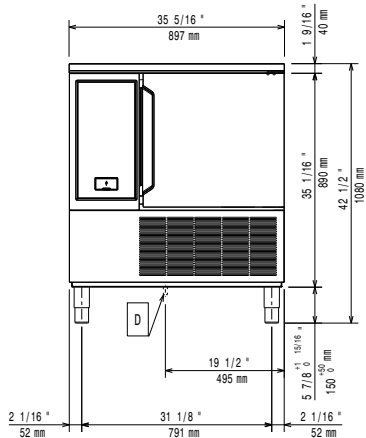

Side

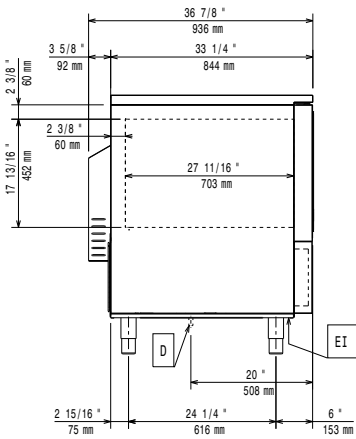

EI = Electrical connection

Top

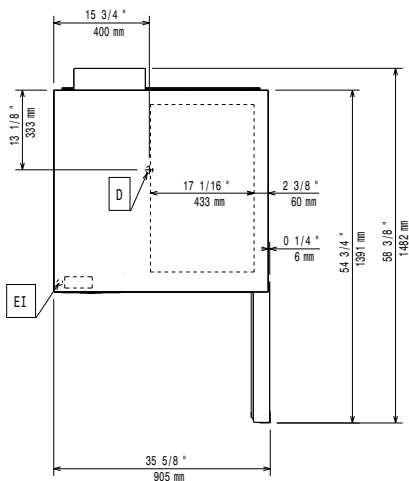

Electric

Supply voltage:

727731 (EBFA61TQ) 208 V/3 ph/60 Hz

Electrical power, default:

3.2 kW

Heating power:

0.9 kW

Water:

Drain line size

1 1/2" (40 mm)

Installation:

2 in (5 cm) on sides and back.

Clearance:

Please see and follow detailed installation instructions provided with the unit.

Capacity:

Max load capacity:

66 lbs (30 kg)

Hotel pans:

6 - 12" X 20"

Half-size sheet pans:

6 - 13" X 18"

Key Information:

External dimensions, Width:

35 5/16" (897 mm)

External dimensions, Depth:

36 7/8" (936 mm)

External dimensions, Height:

42 1/2" (1080 mm)

Shipping width:

40 15/16" (1040 mm)

Shipping depth:

39 3/8" (1000 mm)

Shipping height:

48 1/32" (1220 mm)

Shipping weight:

423 lbs (192 kg)

Shipping volume:

 44.8 ft³ (1.27 m³)

Refrigeration Data

Refrigeration power at evaporation temperature:

14 °F

Refrigerant weight:

2.535 lbs (1150 g)

Refrigeration power:

16320 BTU/hr

Condensation temperature:

104°F

Ambient temperature:

89,6°F

ISO Certificates

ISO Standards:

ISO 9001; ISO 14001; ISO 45001; ISO 50001

Sustainability

Current consumption:

ISO 9001; ISO 14001 Amps

GWP Index:

1387